

Type-C USB Power Delivery Controller

BM92T30MWV

General Description

BM92T30 is a full function Type-C USB-PD controller that supports USB Power Delivery using base-band communication. It is compatible with USB Type-C specification rev1.1 and USB Power Delivery specification rev2.0.

BM92T30 includes support for the PD policy engine and communicates with an Embedded Controller or the SoC via host interface. It supports SOP, SOP', SOP'' and SOP''' signaling, allowing it to communicate with cable marker ICs, support alternate modes and protocol adapters.

Features

- USB Type-C Spec 1.1 compatible
- USB PD Spec 2.0 compatible (BMC-PHY)
- Two channel power path control using N-channel MOSFET drivers with back flow prevention
- Type C cable orientation detection
- Built-in VCONN Switch and VCONN controller
- Direct VBUS powered operation
- Supports DisplayPort control(HPD)
- Supports Deep-Sleep-Mode (PC Application)
- Supports DFP/UFP/DRP mode.
- Supports Dead Battery operation.
- Supports analog audio headphone detection
- Support for controlling multiplexers and switches based on internal status registers

- SMBus Interface for Host Communication
- EC-less Operation (Auto mode)

Applications

- Consumer Applications
 - Laptop PCs, Tablet PCs, Desktop PCs

Key Specifications

- VBUS Voltage Range: 4.75V to 20V
- Power Sink Voltage Range: 4.75V to 20V
- Power Source Voltage Range: 4.75V to 20V
- Power Consumption at Low Power: 0.4m W (Typ)
- Operating Temperature Range: -30°C to +105°C

Package

W (Typ) x D (Typ) x H (Max)
UQFN40V5050A 5.00mm x 5.00mm x 1.00mm



Typical Application Circuit(s)

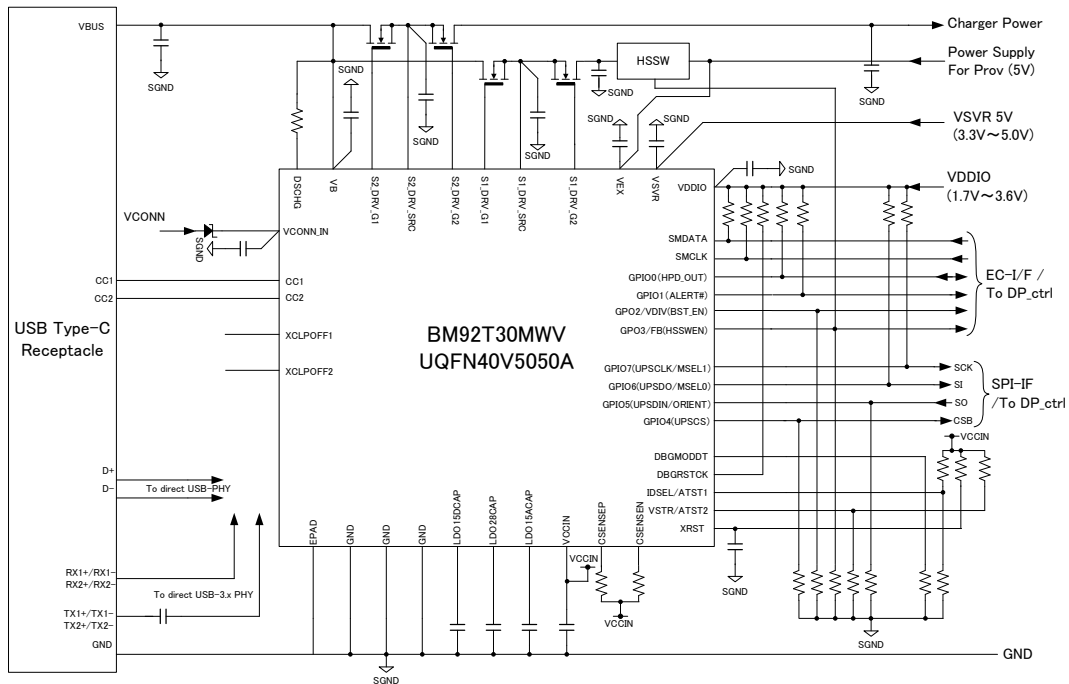

Figure A. Typical Application Circuit

○Product structure : Silicon monolithic integrated circuit ○This product has no designed protection against radioactive rays

Contents

Contents2

Notation3

Reference3

1 Introduction4

2 Pin Description5

3 Pin Configuration7

4 Package Dimensions8

5 Electrical Characteristics9

5.1 Absolute Maximum Ratings9

5.2 Recommended Operating Conditions10

5.3 Circuit Current Characteristics10

5.4 Digital Pin DC Characteristics11

5.5 Power supply management12

5.5.1 Outline12

5.5.2 Electrical Characteristics13

5.6 CC_PHY14

5.6.1 Outline14

5.6.2 Electrical Characteristics16

Table 5-6. CC_PHY Characteristics16

5.7 Voltage detection17

5.7.1 Outline17

5.7.2 Electrical Characteristics17

Table 5-7. Voltage Detection characteristics17

5.8 VBUS Discharge18

5.8.1 Outline18

5.8.2 Electrical Characteristics18

Table 5-8. VBUS Discharge Characteristics18

5.9 Power FET Gate Driver (SINK & SOURCE)19

5.9.1 Outline19

5.9.2 Electrical Characteristics19

Table 5-9. Power FET Gate Driver Characteristics19

5.10 Power On Sequence20

5.11 Power Off Sequence21

5.12 I/O Equivalence Circuit22

6 Application Example25

6.1 Selection of Components Externally connected25

7 Function Description25

8 Application Circuits for Different Firmware Types25

9 Operational Notes26

Notation

Category	Notation	Description
Unit	V	Volt (Unit of voltage)
	A	Ampere (Unit of current)
	Ω, Ohm	Ohm (Unit of resistance)
	F	Farad (Unit of capacitance)
	deg., degree	degree Celsius (Unit of Temperature)
	Hz	Hertz (Unit of frequency)
	s (lower case)	second (Unit of time)
	min	minute (Unit of time)
	b, bit	bit (Unit of digital data)
	B, byte	1 byte = 8 bits
Unit prefix	M, mega-, mebi-	$2^{20} = 1,048,576$ (used with "bit" or "byte")
	M, mega-, million-	$10^6 = 1,000,000$ (used with "Ω" or "Hz")
	K, kilo-, kibi-	$2^{10} = 1,024$ (used with "bit" or "byte")
	k, kilo-	$10^3 = 1,000$ (used with "Ω" or "Hz")
	m, milli-	10^{-3}
	μ, micro-	10^{-6}
	n, nano-	10^{-9}
	p, pico-	10^{-12}
Numeric value	xxh, xxH	Hexadecimal number. "x": any alphanumeric of 0 to 9 or A to F.
	xxb	Binary number; "b" may be omitted. "x": a number, 0 or 1 "_" is used as a nibble (4-bit) delimiter. (eg. "0011_0101b" = "35h")
Address	#xxh	Address in a hexadecimal number. "x": any alphanumeric of 0 to 9 or A to F.
Data	bit[n]	n-th single bit in the multi-bit data.
	bit[n:m]	Bit range from bit[n] to bit[m].
Signal level	"H", High	High level (over V_{IH} or V_{OH}) of logic signal.
	"L", Low	Low level (under V_{IL} or V_{OL}) of logic signal.
	"Z", "Hi-Z"	High impedance state of 3-state signal.

Reference

Name	Reference Document	Release Date	Publisher
USB Type-C	"USB Type-C Specification Release 1.1"	Apr. 3, 2015	USB.org
USB PD	"Power Delivery Specification Revision2.0 Version1.0"	Aug. 11, 2014	USB.org
SMBus	"System Management Bus (SMBus) Specification Version 2.0"	Aug. 3, 2000	System Management Implementers Forum

1 Introduction

BM92T30 is a full function Type-C USB-PD controller that supports USB Power Delivery using base-band communication. It is compatible with USB Type-C specification rev1.1 and USB Power Delivery specification rev2.0

BM92T30 includes the following functional blocks: Type-C Physical Layer (base-band PHY), BMC encoder / decoder, USB-PD Protocol engine, two N-ch MOSFET switch drivers to control two MOSFETS each, OVP FET and SMBus interface for communicating with the host controller. It requires an external embedded controller that includes Device Policy Manager and GPIOs for Type-C USB-PD operation. BM92T30 is able to operate independently in an AC adapter or in a dead battery condition where the embedded controller is not operational. BM92T30 includes an EEPROM, enabling code updates via the SPI interface during prototyping phase.

BM92T30 controller comes in four variations depending on Technical Note for their circuit design. Please refer for additional details

Figure 1-1 shows the block diagram.

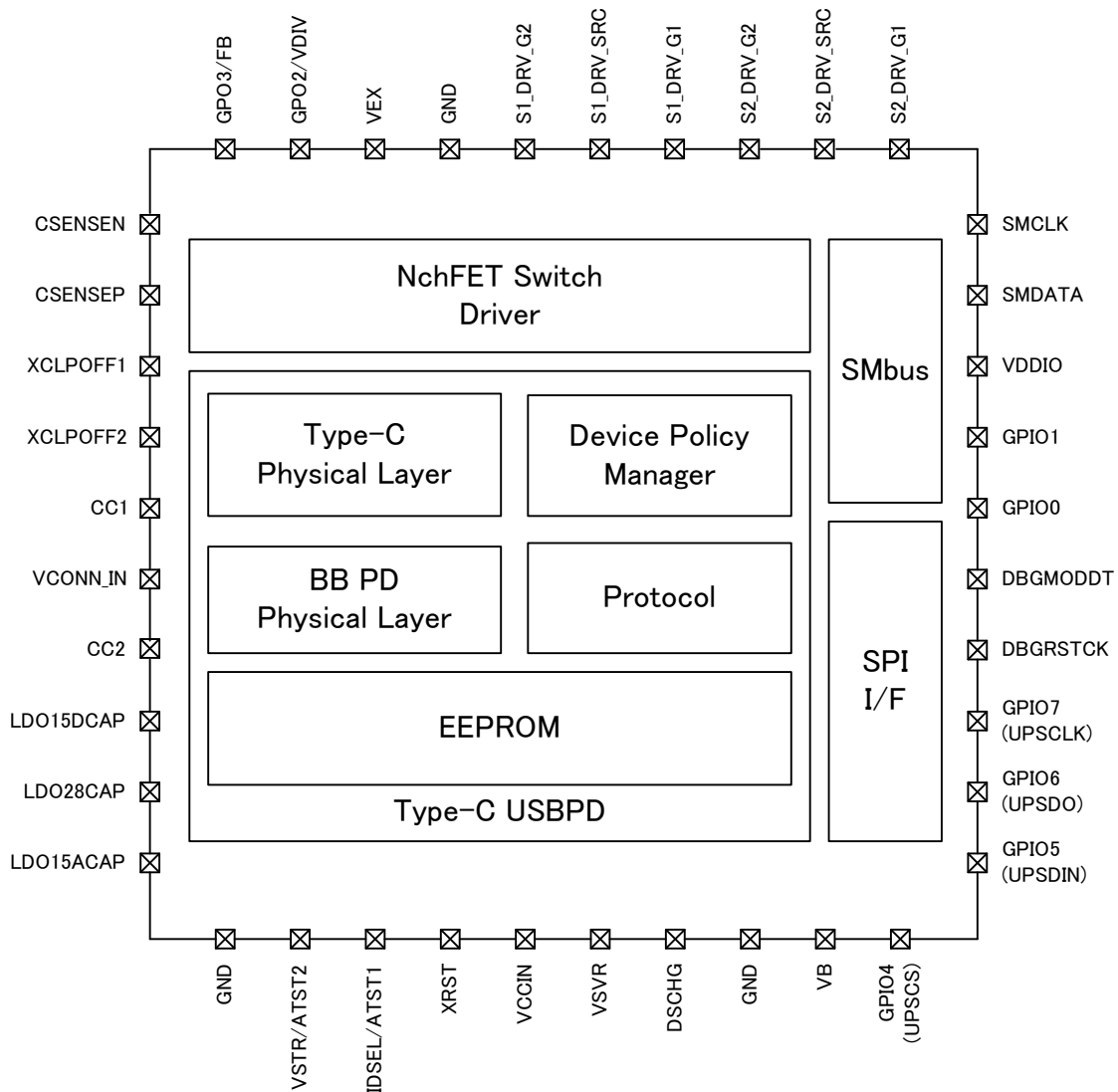

Figure 1-1. Block Diagram

2 Pin Description

Table 2-1. Pin Description

PKG PIN #	Pin Name	BLOCK	I/O	Type	Power System	Description	Note
1	GND	GND	I	GND		Ground	
2	VSTR/ATST2	TEST/Debug	IO	Analog		Analog TEST/ Debug Pin2	
3	IDSEL/ATST1	TEST/Debug	I	Analog		SMBus ID (device address) selection "H":1Ah, "L":18h /Debug Pin1	
4	XRST	Interface	I	Digital	VCCIN	Digital block Reset	
5	VCCIN	USB-PD	O	Analog		Internal Power supply (For internal use, need to connect capacitor to GND)	
6	VSVR	POWER	I	Power		5V SVR INPUT and SPDSRC_FET_SRC voltage	
7	DSCHG	Interface	IO	Analog		Discharge NMOS Drain	
8	GND	GND	I	GND		Ground	
9	VB	POWER	I	Power		Power Source from VBUS	
10	GPIO4 (Ext mode: UPSCS)	Interface	I/O (O)	Digital	VCCIN	General purpose I/O port 4 /(Ext mode: SPI Chip Select)	Refer to Technical Note
11	GPIO5 (Ext mode: UPSDIN)	Interface	I/O (I)	Digital	VCCIN	General purpose I/O port 5 ORIENT /(Ext mode: SPI DATA IN)	Refer to Technical Note
12	GPIO6 (Ext mode: UPSDO)	Interface	I/O (O)	Digital	VCCIN	General purpose I/O port 6 MSEL0 /(Ext mode: SPI DATA OUT)	Refer to Technical Note
13	GPIO7 (Ext mode: UPSCLK)	Interface	I/O (IO)	Digital	VCCIN	General purpose I/O port 7 MSEL1 /(Ext mode: SPI CLK INPUT)	Refer to Technical Note
14	DBGRSTCK	TEST	IO	Digital	VDDIO	Test for logic	
15	DBGMODDT	TEST	IO	Digital	VDDIO	Test for logic	
16	GPIO0	Interface	IO	Digital	VDDIO	General purpose I/O port 0 HPD_OUT	Refer to Technical Note
17	GPIO1	Interface	IO	Digital	VDDIO	General purpose I/O port 1 ALERT#	Refer to Technical Note
18	VDDIO	POWER	I	Power		Interface Voltage (3.3V)	
19	SMDATA	Interface	IO	Digital	VDDIO	SMBus Data	
20	SMCLK	Interface	I	Digital	VDDIO	SMBus Clock	

PKG PIN #	Pin Name	BLOCK	I/O	Type	Power System	Description	Note
21	S2_DRV_G1	FET Gate Control	O	Analog		Power Path FET Gate Control SPDSNK_G1	Refer to Technical Note
22	S2_DRV_SRC	FET Gate Control	I	Analog		Power Path FET BG/SRC Voltage SPDSNK_SRC	Refer to Technical Note
23	S2_DRV_G2	FET Gate Control	O	Analog		Power Path FET Gate Control SPDSNK_G2	Refer to Technical Note
24	S1_DRV_G1	FET Gate Control	O	Analog		Power Path FET Gate Control SPDSRC_G1	Refer to Technical Note
25	S1_DRV_SRC	FET Gate Control	I	Analog		Power Path FET BG/SRC Voltage SPDSRC_SRC	Refer to Technical Note
26	S1_DRV_G2	FET Gate Control	O	Analog		Power Path FET Gate Control SPDSRC_G2	Refer to Technical Note
27	GND	GND	I	GND		Ground	
28	VEX	POWER	I	Power		Extension Power Input	
29	GPO2/VDIV	Interface	O /IO	Digital /Analog	VCCIN	General purpose Output port 2 BST_EN function	
30	GPO3/FB	Interface	O /IO	Digital /Analog	VCCIN	General purpose Output port 3 HSSWEN function	
31	CSENSEN	CDET	I	Analog	VCCIN	Current Sense Voltage Input Negative / Pin 29,30 Configuration *(Pin31,Pin32)=(H,H):GPO mode, other case: Current Sense mode.	
32	CSENSEP	CDET	I	Analog	VCCIN	Current Sense Voltage Input Positive / Pin 29,30 Configuration *(Pin31,Pin32)=(H,H):GPO mode, other case: Current Sense mode.	
33	XCLPOFF1	CCPHY	I	Analog	VCCIN	Disable Clamper of CC1 L:Dead-battery not support Open: Dead-battery support	
34	XCLPOFF2	CCPHY	I	Analog	VCCIN	Disable Clamper of CC2 L:Dead-battery not support Open: Dead-battery support	
35	CC1	CCPHY	IO	Analog		Configuration channel 1 for Type-C	
36	VCONN_IN	CCPHY	I	Analog		Input power for VCONN	
37	CC2	CCPHY	IO	Analog		Configuration channel 2 for Type-C	
38	LDO15DCAP	POWER	O	Analog		Internal LDO 1.5V for Digital Need Capacitor	
39	LDO28CAP	POWER	O	Analog		Internal LDO 2.8V for Analog Need Capacitor	
40	LDO15ACAP	POWER	O	Analog		Internal LDO 1.5V for Analog Need Capacitor	

3 Pin Configuration

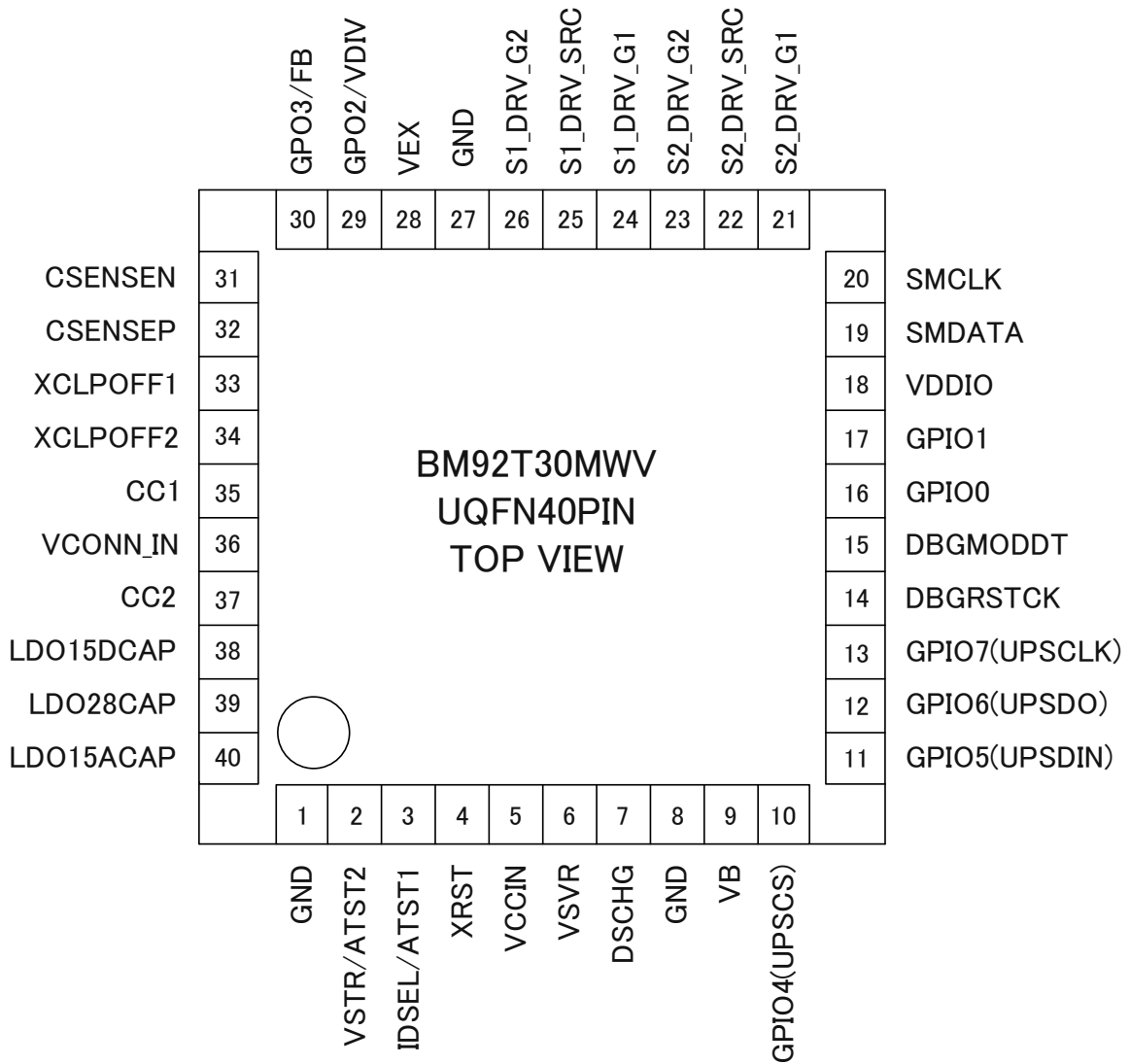

Figure 3-1. Pin configuration

4 Package Dimensions

Ordering Information

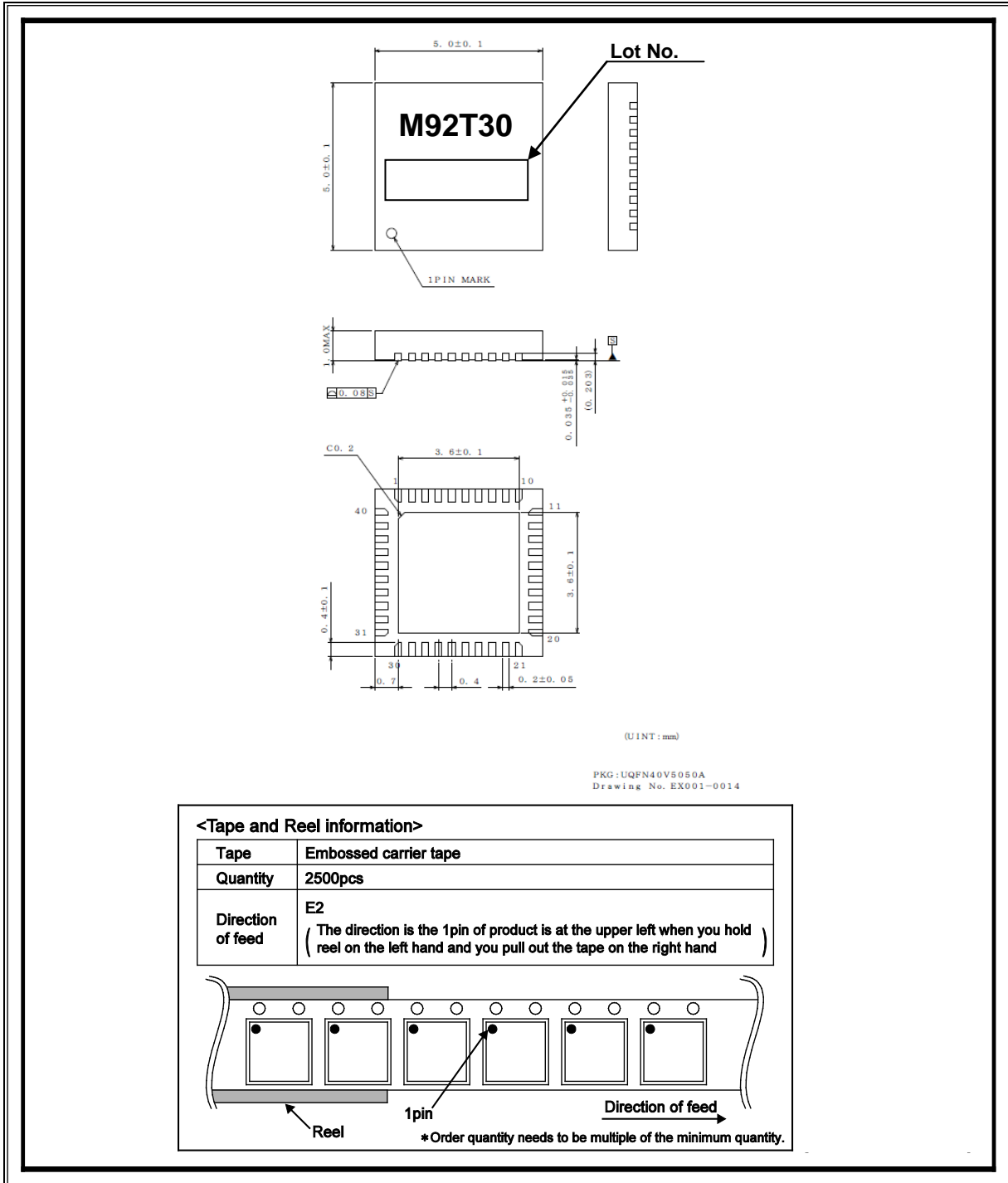
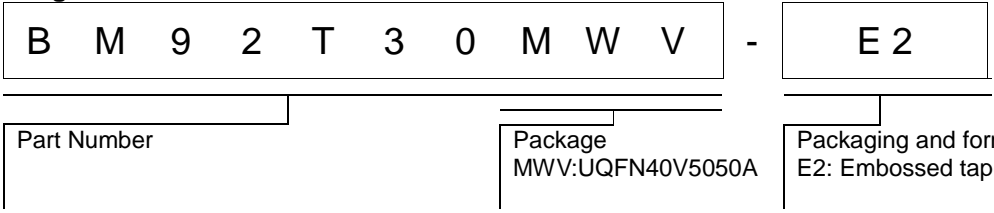

Figure 4-1. UQFN40V5050A Package Dimensions

5 Electrical Characteristics

5.1 Absolute Maximum Ratings

Table 5-1. Absolute Maximum Ratings

(Ta=25°C)

Parameter	Symbol	Rating	Unit	Conditions
Maximum Supply Voltage1 (VB, VEX, DSCHG, S2_DRV_G1, S2_DRV_G2,S2_DRV_SRC, S1_DRV_G1,S1_DRV_SRC, S1_DRV_G2)	VIN1	-0.3 to +28	V	*1 *2
Maximum Supply Voltage2 (VDDIO)	VIN2	-0.3 to +6.0	V	
Maximum Supply Voltage3 (VSVR, DBGRSTCK, DBGMODDT, GPIO0, GPIO1, SMDATA, SMCLK, VCONN_IN)	VIN3	-1.0 to+6.0	V	
Maximum Supply Voltage4 (VSTR/ATST2, IDSEL/ATST1, XRST, VCCIN, GPIO4, GPIO5,GPIO6,GPIO7, GPO2/VDIV, GPO3/FB, CSENSEN, CSENSEP, XCLPOFF1, XCLPOFF2, CC1, CC2, LDO15DCAP, LDO28CAP, LDO15ACAP,)	VIN4	-0.3 to +6.0	V	
Maximum different Voltage (S2_DRV_G1-S2_DRV_SRC, S2_DRV_G2-S2_DRV_SRC, S1_DRV_G1-S1_DRV_SRC, S1_DRV_G2-S1_DRV_SRC)	Vdiff	-0.3 to +6.0	V	
Power Dissipation	Pd	2.61	W	*3
Operating Temperature Range	Topr	-30 to +105	degree	*4
Storage Temperature Range	Tstg	-55 to +125	degree	

*1 When the DSCHG pin is applied voltage should by way of resistance more than 120Ω (4W).

*2 The different voltage between S*DRV_G* and S*DRV_SRC is defined "Symbol Vdiff". S*_DRV_G*=S*_DRV_SRC+5.8V (typ.)

*3 This value is the permissible loss using a ROHM specification board (74.2 x 74.2 x 1.6mm, 4 layered board mounting).

At the time of PCB mounting the permissible loss varies with the size and material of board.

When using more than at Ta=25°C, it is reduced 26.1 mW per 1°C. (Caution) Use in excess of this value may result in damage to the device. Moreover, normal operation is not protected.

*4 Target spec.

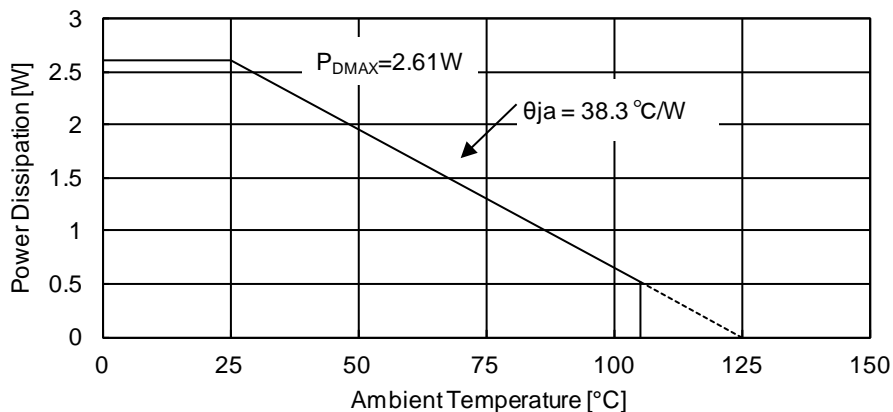

Figure 5-1. Power Dissipation

5.2 Recommended Operating Conditions

Table 5-2. Recommended Operating Conditions

(Ta=25°C)

Item	Symbol	Range	Unit	Conditions
VB, VEX Voltage	VB, VEX	4.75 ~ 20	V	
VSVR Voltage	VSVR	3.1 ~ 5.5	V	*2
VDDIO Voltage	VDDIO	1.7 ~ 5.5	V	*2
VCONN_IN Input Voltage	VCONN	4.75 ~ 5.5	V	

*2 target design

5.3 Circuit Current Characteristics

Table 5-3. Common Characteristics

Electrical Characteristics (Ta=25°C, VSVR=3.3V, VB=open, VEX=open, VDDIO=3.3V)

Item	Symbol	Limit			Unit	Conditions
		Min	Typ	Max		
[Circuit Current]						
Unattached current	Idd_unatt		0.4		mW	@VSVR=3.3V
Attached current	Idd_att		3.5		mW	@VSVR=3.3V

5.4 Digital Pin DC Characteristics

Table5-4. Digital Pin DC Characteristics

Electrical Characteristics (Ta=25°C, VSVR=3.3V, VB=open, VEX=open, VDDIO=3.3V, VCCIN=VSVR)

Item	Symbol	Limit			Unit	Comment
		Min	Typ	Max		
[Digital characteristics Power: VDDIO] (Input Digital Pins: SMCLK, DBGRSTCK) (Input/ Output Pins: GPIO0, GPIO1, SMDATA, DBGMODDT)						
Input "H" level (SMCLK, SMDATA)	VIH1	0.8× VDDIO	-	VDDIO+0 .3	V	
Input "L" level (SMCLK, SMDATA)	VIL1	-0.3	-	0.2× VDDIO	V	
Input leak current (SMCLK, SMDATA)	IIC1	-5	0	5	µA	Power: VDDIO
Input "H" level (other Digital input)	VIH2	0.8× VDDIO	-	VDDIO+0 .3	V	
Input "L" level (other Digital input)	VIL2	-0.3	-	0.2× VDDIO	V	
Input leak current (other Digital input)	IIC2	-1	0	1	µA	Power: VDDIO
SMDATA pin "L" level voltage	VOL SMDATA	-	-	0.4	V	IOL=350uA Max
Output Voltage when "L" (other Digital output)	VOL1	-	-	0.3	V	Source=1mA
OFF Leakage Current (other Digital output)	IIOFF1	-3	-	3	µA	VIN=VDDIO
[Digital characteristics Power: VCCIN] (Input Digital Pins: XRST) (Input/ Output Pins:GPIO4, GPIO5, GPIO6, GPIO7) (Output Pins: GPO2/VDIV, GPO3/FB)						
Input "H" level (XRST,GPIOs)	VIH3	0.8× VCCIN	-	VCCIN+0. 3	V	
Input "H" level(XRST,GPIOs)	VIH3	0.8× VCCIN	-	VCCIN+0. 3	V	
Input "L" level (XRST,GPIOs)	VIL3	-0.3	-	0.2× VDDIO	V	
Input leak current (XRST,GPIOs)	IIC3	-5	0	5	µA	Power: VCCIN
Input "H" level (other Digital input)	VIH4	0.8× VDDIO	-	VDDIO+0 .3	V	
Input "L" level (other Digital input)	VIL4	-0.3	-	0.2× VDDIO	V	Power: VCCIN
Input leak current (other Digital input)	IIC4	-1	0	1	µA	
Output Voltage when "L" (other Digital output)	VOL2	-	-	0.3	V	Source=1mA
OFF Leakage Current (other Digital output)	IIOFF2	-3	-	3	µA	VIN=VCCIN CSENSEP=CSENS EN=VCCIN

5.5 Power supply management

5.5.1 Outline

This LSI has a power selector. It select the lowest power supply voltage from VSVR, VEX, or VB for low power consumption. Internal Power Supply (VCCIN) gives priority in order of VSVR, VEX, and VB. VCCIN supplied from the power selector is used to LSI main power source. LDOs (for internal only) are supplied from VCCIN, and output each internal supply voltage.

Each power supply input have UVLO (2.8Vtyp) and OVLO (VSVR: 6.4Vtyp, VEX/VB: 6.4/15.0/28.0Vtyp).And POR (power on reset) signal is generated from detection of LDO28OK, LDO15DOK, LDO15AOK, and VCCIN.

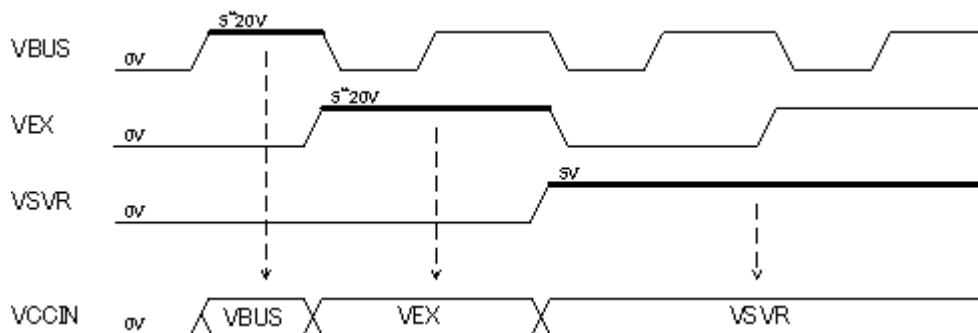
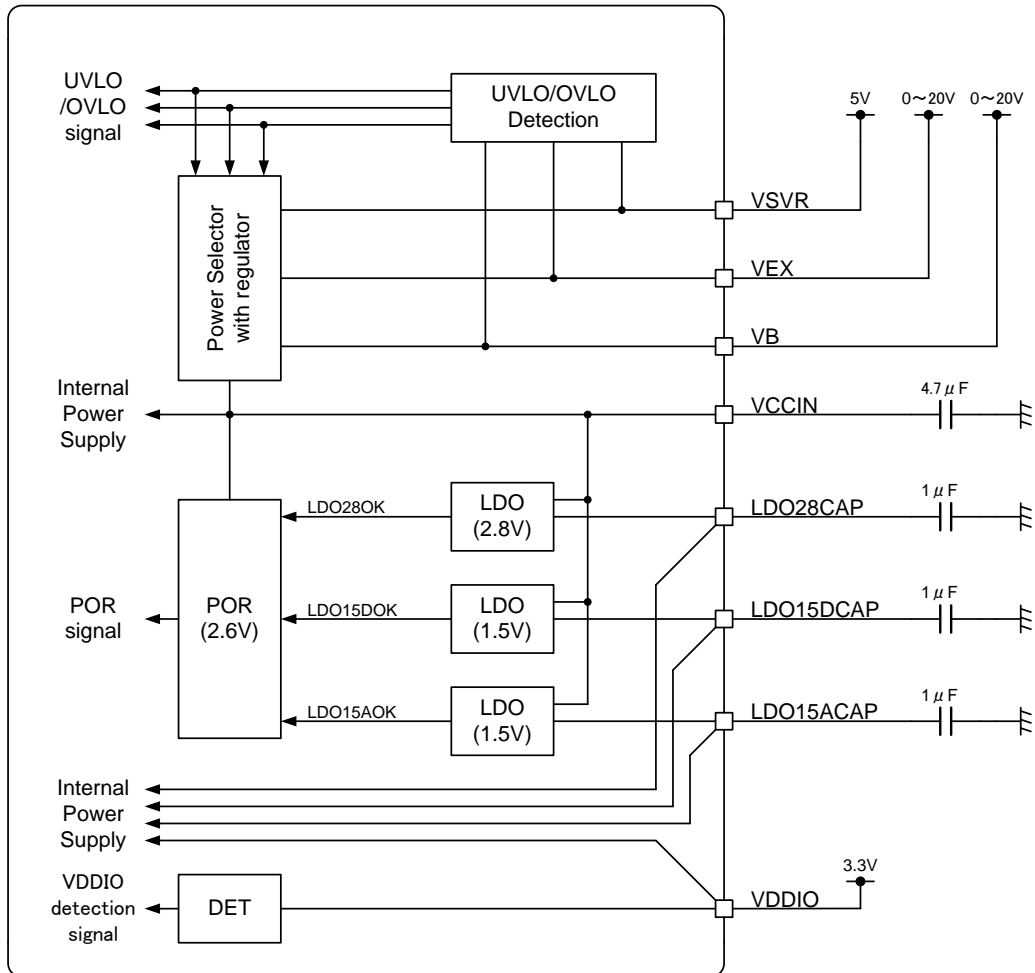

Figure 5-2. Power Supply Management Block Diagram and Timing Chart

5.5.2 Electrical Characteristics

Table 5-5. Power Supply Management Characteristics

Item	Symbol	Limit			Unit	Comment
		Min	Typ	Max		
[Analog characteristics] Unless otherwise specified Ta=25°C, GND=0V, Bypass Capacitor(VCCIN)=4.7μF, Bypass Capacitors(LDO28CAP, LDO15DCAP, LDO15ACAP) =1μF Input Analog Pins: VSVR, VEX, VB						
UVLO release voltage	UVLO1H	-	2.8	-	V	VSVR, VEX, VB=up
UVLO detect voltage	UVLO1L	-	2.7	-	V	VSVR, VEX, VB=down
OVLO detect voltage (5V mode)	OVLO5	-	6.4	-	V	VSVR, VEX, VB=up
OVLO detect voltage (12V mode)	OVLO12	-	15	-	V	VEX, VB=up
OVLO detect voltage (20V mode)	OVLO20	-	28	-	V	VEX, VB=up
OVLO hysteresis voltage (5V mode)	OVLO5hys	-	240	-	mV	OVLO5-release voltage
OVLO hysteresis voltage (12V mode)	OVLO12hys	-	580	-	mV	OVLO12-release voltage
OVLO hysteresis voltage (20V mode)	OVLO20hys	-	580	-	mV	OVLO20-release voltage
Power ON reset threshold voltage	POR	-	2.6	-	V	VCCIN=up
LDO28CAP output voltage	V28	-	2.8	-	V	No Load, VSVR=5V
LDO15DCAP output voltage	V15D	-	1.5	-	V	No Load, VSVR=5V
LDO15ACAP output voltage	V15D	-	1.5	-	V	No Load, VSVR=5V

5.6 CC_PHY

5.6.1 Outline

CC_PHY has below functions of USB Type-C. (Refer to USB Type-C Spec)

- Defining Port Mode
 - > DFP Mode Condition
 - > UFP Mode Condition
 - > DRP Mode Condition
- DFP-to-UFP Attach / Detach Detection
- Plug Orientation / Cable Twist Detection
- USB Type-C VBUS Current Detection and Usage
- VCONN (Supply for SOP') Control
- Base-Band Power Delivery Communication (BBPD communication)
- Discovery and Configuration of Functional Extensions

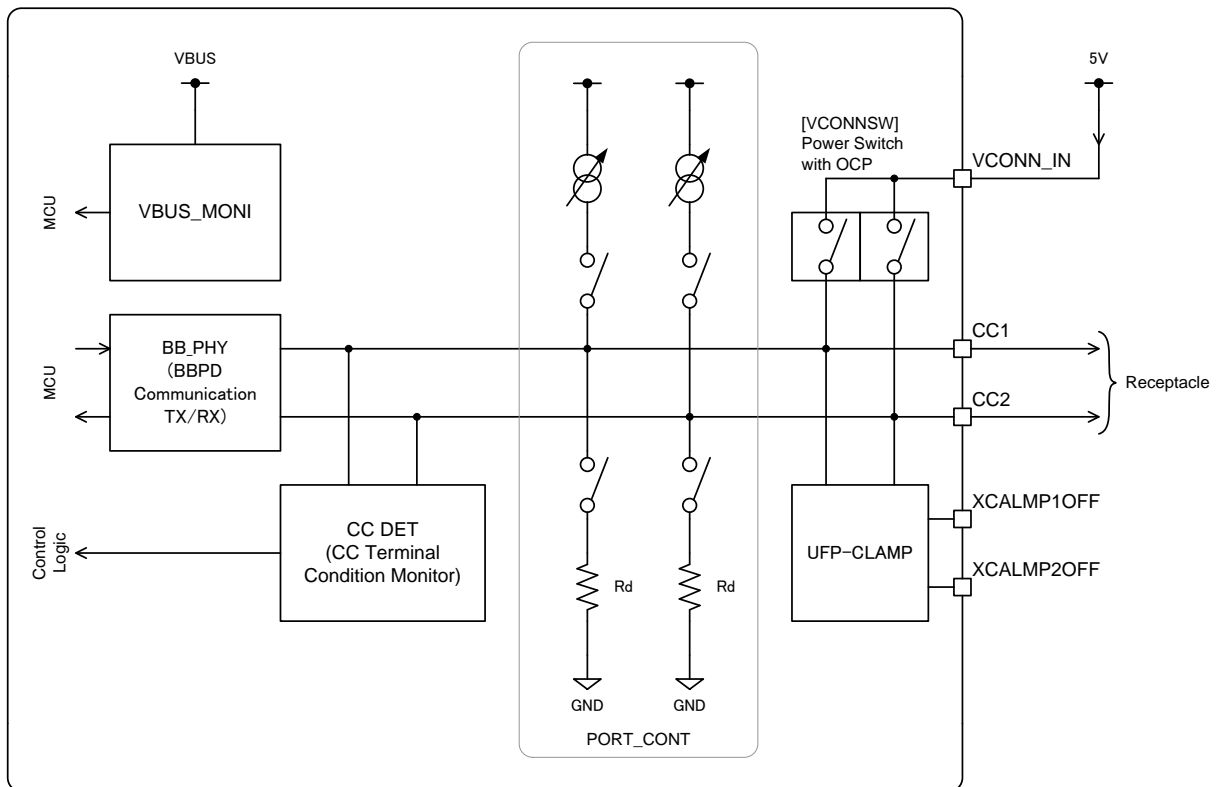

Figure 5-3. CC_PHY Block Diagram

[PORT_CONT]

This block chose the port mode according to the setting from MCU.

(DFP)

Variable current source is connected to CC terminal. These currents of each mode are 80 μ A \pm 20%: Default Current, 180 μ A \pm 8%: Medium Current and 330 μ A \pm 8%: High Current.

(UFP)

Pull-down resistor (Rd=5.1k Ω \pm 10%) is connected to CC terminal.

(DRP)

Changing DFP and UFP is repeated frequently.

[CC_DET]

CC_DET has functions of "Attach / Detach Detection", "Plug Orientation / Cable Twist Detection", "Discovery and detect extension mode" and "USB Type-C VBUS Current Detection".

Attach / Detach is detected with monitoring voltage of CC terminal. When the voltage of CC terminal become under a threshold voltage at DFP, attach is detected. Oppositely, when the voltage of CC terminal become over a threshold voltage, detach is detected. When the voltage of CC terminal become over a threshold voltage at UFP, attach is detected.

Plug orientation and cable twist is detected from the relationship of two CC terminals. Because only one wire is connected to Rd, the difference between two CC terminals is generated.

UFP can detect the maximum current of the power source by monitoring the voltage of CC terminal.

It is possible to detect extension mode because DFP can detect Ra at Attach / Detach detection.

[UFP_CLAMP]

1.1V Clamp is used for UFP emulation at dead-battery condition.

[VBUS_MONI]

UFP detect Attach / Detach by existence of VBUS voltage. VBUSDET detects Attach when VBUS voltage over the threshold voltage. And it detects Detach when VBUS under the threshold voltage.

[VCONNSW]

VCONNSW is the power switch for VCONN source. It has OCP (1.3A typ) function.

[BB_PHY]

If Type-C controller supports BBPD, CC terminal can output BBPD communication signal. (Refer to BB_PHY)

5.6.2 Electrical Characteristics

Table 5-6. CC_PHY Characteristics

Item	Symbol	Limit			Unit	Comment
		Min	Typ	Max		
[PORT_CONT characteristics] Unless otherwise specified Ta=25°C, VSVR=VEX=VB=5V, VCONN_IN=5V, VDDIO=3.3V, GND=0V, Bypass Capacitor(VCCIN)=4.7µF, Bypass Capacitors(LDO28CAP, LDO15DCAP, LDO15ACAP) =1µF Input Analog Pins: CC1, CC2, VCONN_IN						
Pull up current 1	CCPUP1	64	80	96	µA	Ta=-30~105°C
Pull up current 2	CCPUP2	166	180	194	µA	Ta=-30~105°C
Pull up current 3	CCPUP3	304	330	356	µA	Ta=-30~105°C
Pull down resistor	CCPDN	4.6	5.1	5.6	kΩ	Ta=-30~105°C
[UFP_CLAMP characteristics] Unless otherwise specified Ta=25°C, VSVR=VEX=VB=5V, VCONN_IN=5V, VDDIO=3.3V, GND=0V, Bypass Capacitor(VCCIN)=4.7µF, Bypass Capacitors(LDO28CAP, LDO15DCAP, LDO15ACAP) =1µF Input Analog Pins: CC1, CC2, VCONN_IN						
CCx terminal input impedance	CCZin	126	-	-	kΩ	
CCx clamp voltage	CCCLP	0.7	-	1.3	V	Iin=80 to 330µA
[VBUS MONI] Unless otherwise specified Ta=25°C, VSVR=VEX=VB=5V, VCONN_IN=5V, VDDIO=3.3V, GND=0V, Bypass Capacitor(VCCIN)=4.7µF, Bypass Capacitors(LDO28CAP, LDO15DCAP, LDO15ACAP) =1µF Input Analog Pins: CC1, CC2, VCONN_IN						
VBUS presence detection level	CCVBDET	-	3.42	-	V	
[VCONNSW] Unless otherwise specified Ta=25°C, VSVR=VEX=VB=5V, VCONN_IN=5V, VDDIO=3.3V, GND=0V, Bypass Capacitor(VCCIN)=4.7µF, Bypass Capacitors(LDO28CAP, LDO15DCAP, LDO15ACAP) =1µF Input Analog Pins: CC1, CC2, VCONN_IN						
VCONN_IN to CCx resistance	CCVCR	-	-	500	mΩ	
Overcurrent protection level	CCVCOCP	1.1	-	-	A	
[BB_PHY] Unless otherwise specified Ta=25°C, VSVR=VEX=VB=5V, VCONN_IN=5V, VDDIO=3.3V, GND=0V, Bypass Capacitor(VCCIN)=4.7µF, Bypass Capacitors(LDO28CAP, LDO15DCAP, LDO15ACAP) =1µF Input Analog Pins: CC1, CC2, VCONN_IN						
TX BCM frequency	fBCTX		300		kHz	
TX voltage output H level	BBVOH	1.05	-	1.2	V	
TX voltage output L level	BBVOL	0	-	75	mV	
RX voltage input H level	BBVIH	-	0.6	0.65	V	
RX voltage input L level	BBVIL	0.45	0.5	-	V	

5.7 Voltage detection

5.7.1 Outline

VDET Block detects the voltage level of VBUS or VEX. It can detect follow conditions; (1) the voltage over the protection level, (2) the voltage over the setting range and (3) the voltage under the setting range.

- VBUS or VEX voltage Detection for PDO of USB-PD spec.
- OVP (over voltage protection) Detection: $V_{nom} + 20\%_{typ}$
- OVR (over voltage range) Detection: $V_{nom} + 5\%_{typ}$
- UVR (under voltage range) Detection: $V_{nom} - 5\%_{typ}$

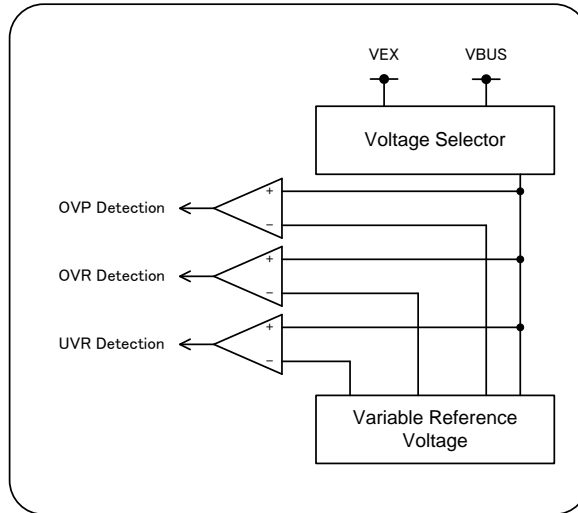

Figure 5-4. Voltage Detection Block Diagram

5.7.2 Electrical Characteristics

Table 5-7. Voltage Detection characteristics

Item	Symbol	Limit			Unit	Comment
		Min	Typ	Max		
[VDET characteristics] Unless otherwise specified $T_a=25^{\circ}\text{C}$, $V_{SVR}=V_{EX}=V_B=5\text{V}$, $V_{CONN_IN}=V_{CCIN}$, $V_{DDIO}=3.3\text{V}$, $GND=0\text{V}$, Bypass Capacitor(V_{CCIN})= $4.7\mu\text{F}$, Bypass Capacitors($LDO28\text{CAP}$, $LDO15\text{DCAP}$, $LDO15\text{ACAP}$) = $1\mu\text{F}$, $V_{nom}=5\text{V}$ Input Analog Pins: VEX, VB						
Over voltage protection detection rate	OVP	17	20	23	%	Standard voltage= V_{nom}
Over voltage range detection rate	OVR	3	5	7	%	Standard voltage= V_{nom}
Under voltage range detection rate	UVR	-7	-5	-3	%	Standard voltage= V_{nom}

5.8 VBUS Discharge

5.8.1 Outline

NMOS switch is prepared for VBUS discharging.

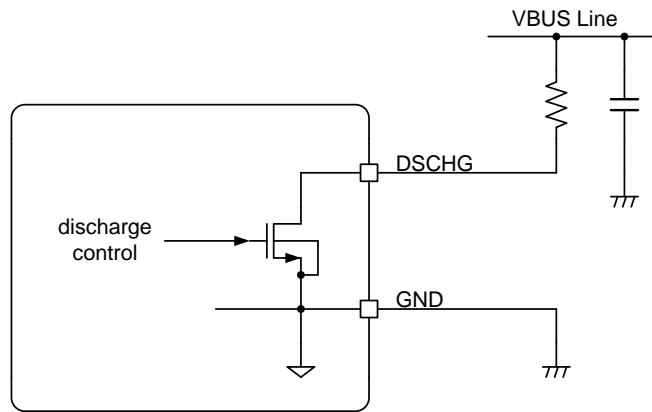

Figure 5-5. VBUS Discharge Block Diagram

5.8.2 Electrical Characteristics

Table 5-8. VBUS Discharge Characteristics

Item	Symbol	Limit			Unit	Comment
		Min	Typ	Max		
[Discharge characteristics] Unless otherwise specified Ta=25°C, VSVR=VEX=VB=5V, VCONN_IN=VCCIN, VDDIO=3.3V, GND=0V, Bypass Capacitor(VCCIN)=4.7μF, Bypass Capacitors(LDO28CAP, LDO15DCAP, LDO15ACAP) =1μF Input Analog Pins: DSCHG						
Discharge Resistor	RDSCHG	-	25	-	Ω	

5.9 Power FET Gate Driver (SINK & SOURCE)

5.9.1 Outline

FET Gate Driver is the NMOS switch driver for power line switch.

- External Nch-FET gate control: S1, S2
- One of two DC input selection

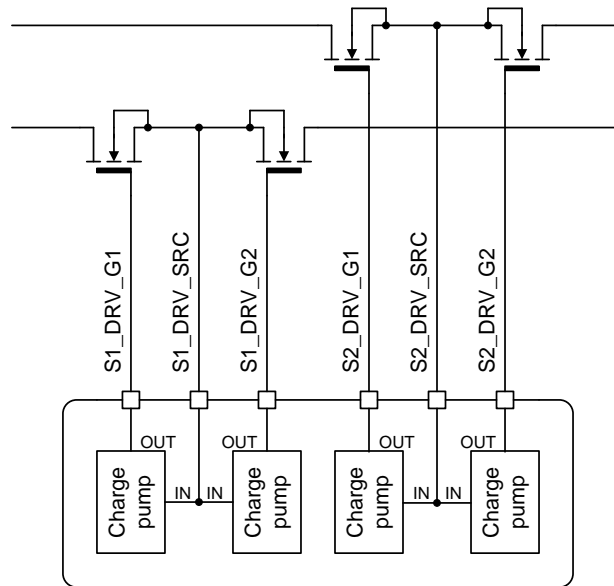

Figure 5-6. Power FET Gate Driver Block Diagram

5.9.2 Electrical Characteristics

Table 5-9. Power FET Gate Driver Characteristics

Item	Symbol	Limit			Unit	Comment
		Min	Typ	Max		
[Discharge characteristics] Unless otherwise specified Ta=25°C, VSVR=VEX=VB=5V, VCONN_IN=VCCIN, VDDIO=3.3V, GND=0V, Bypass Capacitor(VCCIN)=4.7μF, Bypass Capacitors(LDO28CAP, LDO15DCAP, LDO15ACAP) =1μF Input Analog Pins: S1_DRV_SRC, S2_DRV_SRC Output Analog Pins: S1_DRV_G1, S1_DRV_G2, S2_DRV_G1, S2_DRV_G2						
FET control voltage between gate and source	VGS	-	6.0	-	V	S1_DRV_G1 – S1_DRV_SRC S1_DRV_G2 – S1_DRV_SRC S2_DRV_G1 – S2_DRV_SRC S2_DRV_G2 – S2_DRV_SRC

5.10 Power On Sequence

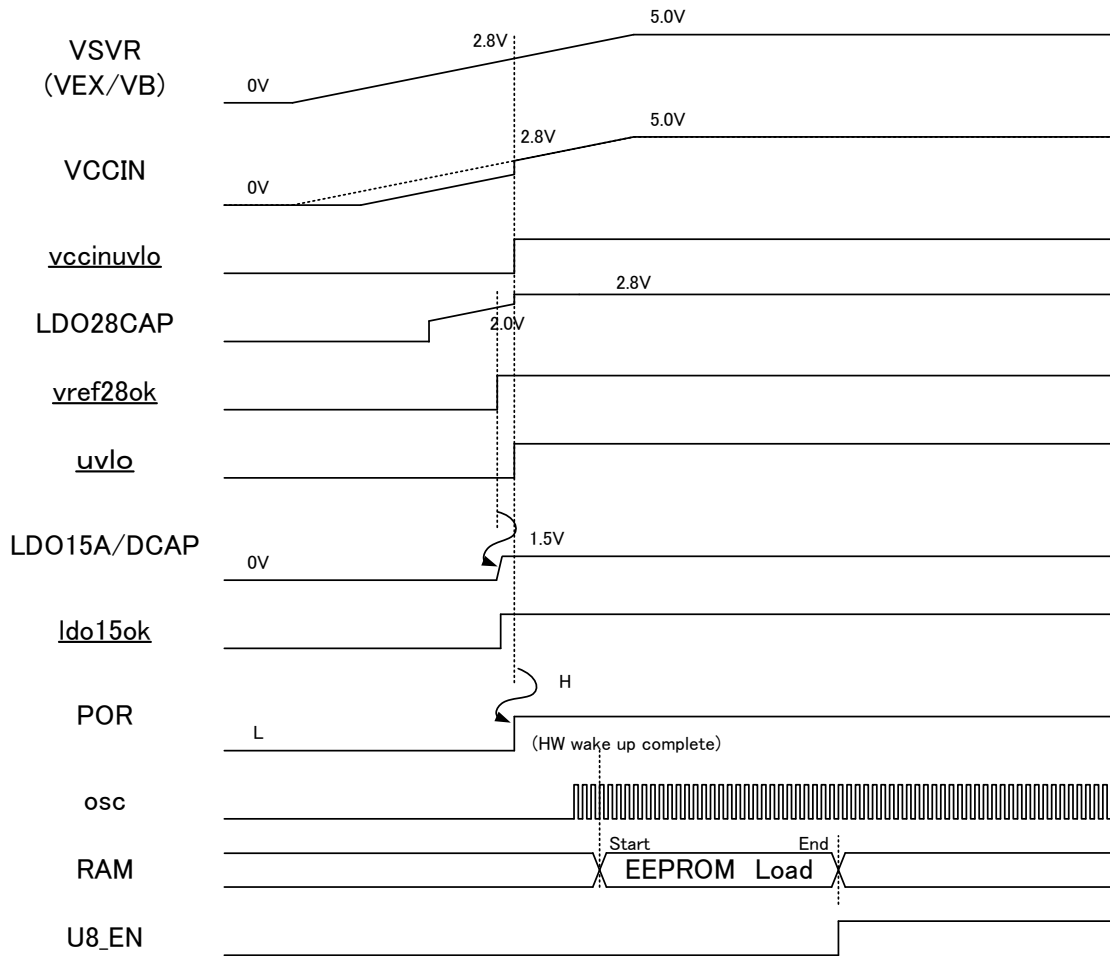

Figure 5-8. Power On Sequence

5.11 Power Off Sequence

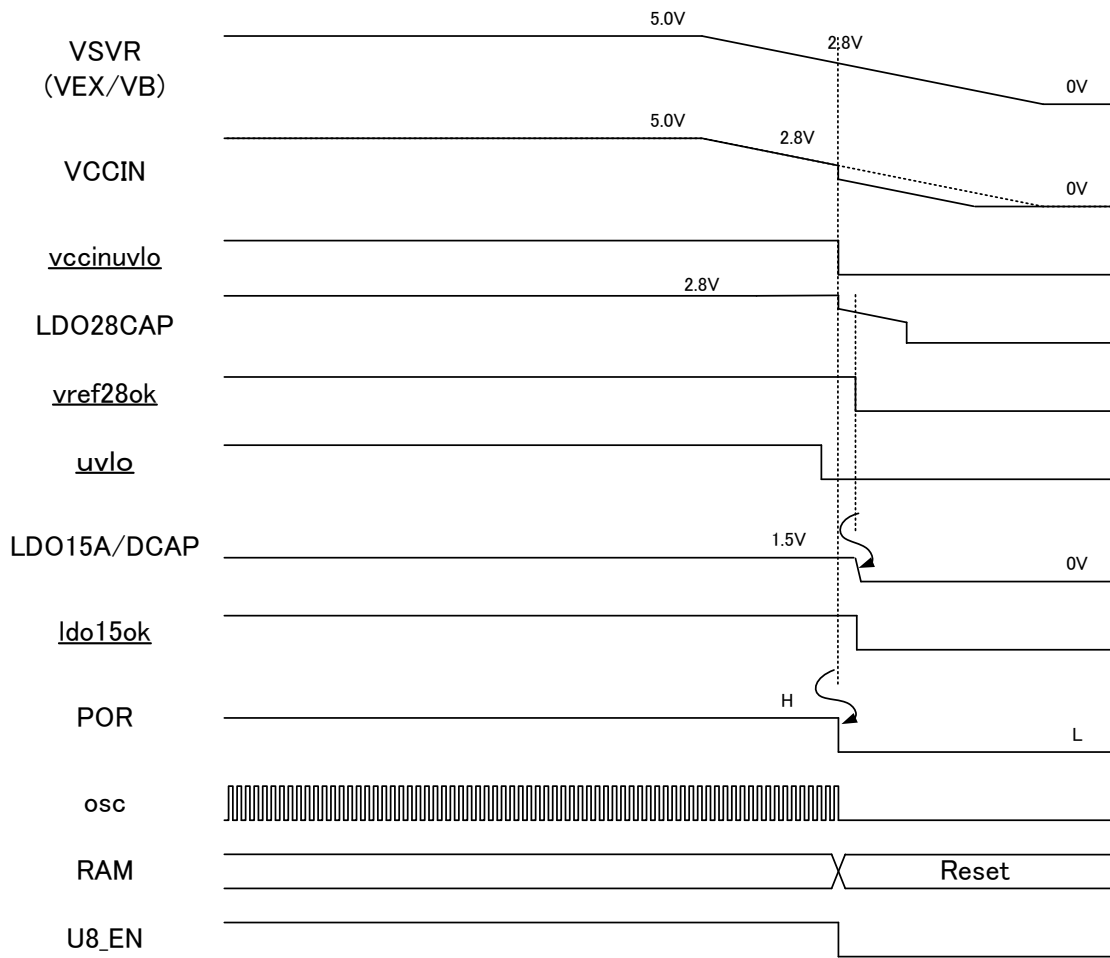
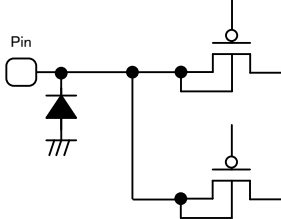
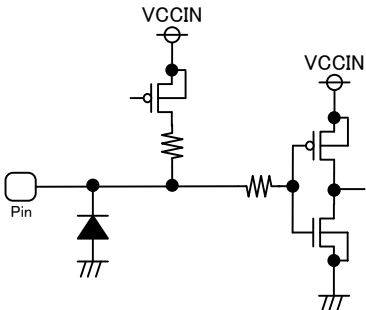
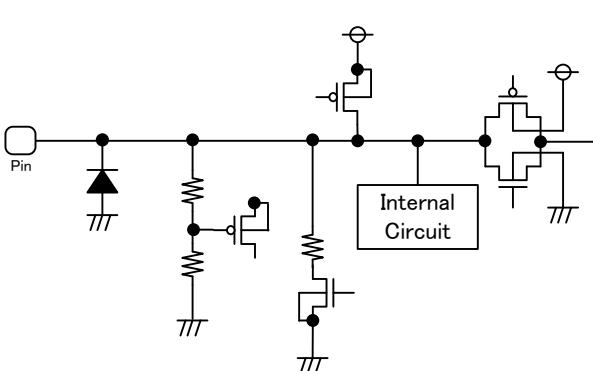
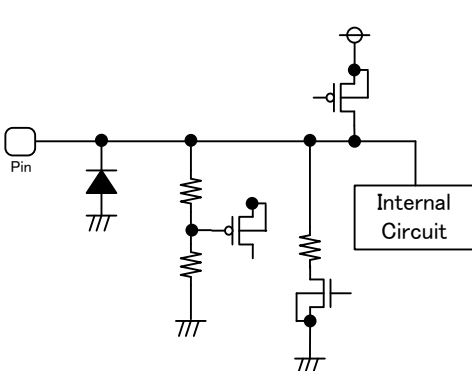
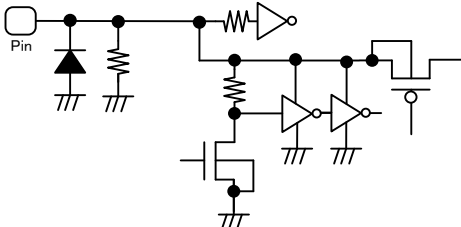
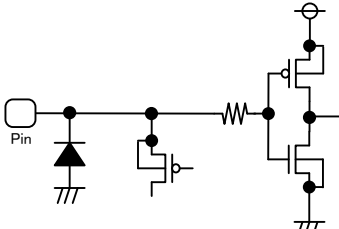

Figure 5-9. Power Off Sequence

5.12 I/O Equivalence Circuit

PIN No.	PIN Name	Equivalent circuit diagram
6 9 28	VSVR VB VEX	
7	DSCHG	
5	VCCIN	
16 17 15 14 10 11 12 13	GPIO0(VIN_EN) GPIO1(ALERT#) DBGMODDT DBGRSTCK GPIO4(UPSCS) GPIO5(UPSDIN) GPIO6(UPSDO) GPIO7(UPSCLK)	
29	GPO2_VDIV	
30	GPO3_FB	
18	VDDIO	

<p>32 31</p>	<p>CSENSEP CSENSEN</p>	
<p>19 21</p>	<p>SMDATA SMCLK</p>	
<p>32 22 23 24 25 26</p>	<p>S2_DRV_G1 S2_DRV_SRC S2_DRV_G2 S1_DRV_G1 S1_DRV_SRC S1_DRV_G2</p>	
<p>33 34</p>	<p>XCLPOFF1 XCLPOFF2</p>	
<p>35 37</p>	<p>CC1 CC2</p>	

36	VCONN_IN	
4	XRST	
38 40	LDO15DCAP LDO15ACAP	
39	LDO28CAP	
2	VSTR/ATST2	
3	IDSEL/ATST1	

6 Application Example

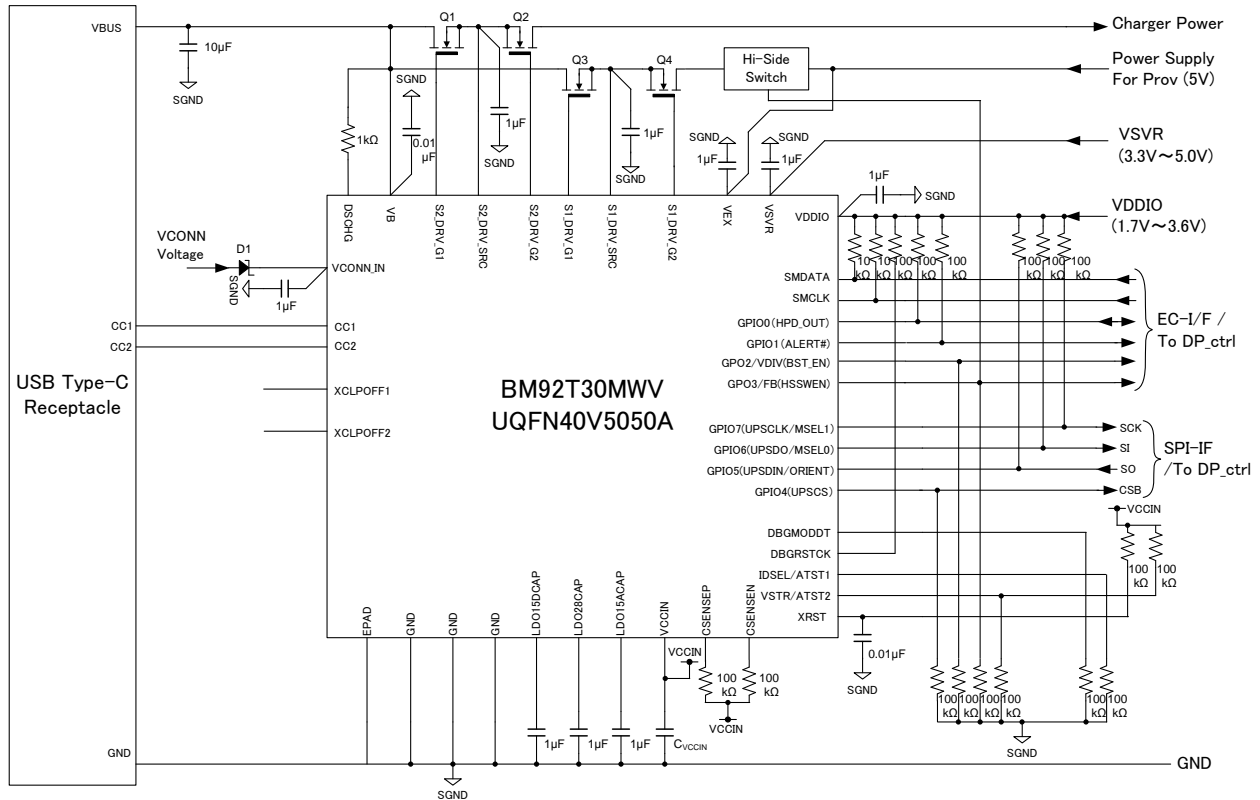

6.1 Selection of Components Externally connected

Item	Symbol	Min	Typ	Max	Unit	Comment
VCCIN Capacitance(*)	C_{VCCIN}	2.2	4.7	10	μF	
Q1,Q2,Q3,Q4 Gate-Source Capacitance	C_{Qx_gs}	220p	-	0.5 μ	F	

(*)Please set the capacity of the condenser not to be less than the minimum in consideration of temperature properties, DC bias properties.

7 Function Description

Please refer to the Technical Note

8 Application Circuits for Different Firmware Types

Please refer to the Technical Note

9 Operational Notes

(1) Reverse Connection of Power Supply

Connecting the power supply in reverse polarity can damage the IC. Take precautions against reverse polarity when connecting the power supply, such as mounting an external diode between the power supply and the IC's power supply pins.

(2) Power Supply Lines

Design the PCB layout pattern to provide low impedance supply lines. Separate the ground and supply lines of the digital and analog blocks to prevent noise in the ground and supply lines of the digital block from affecting the analog block. Furthermore, connect a capacitor to ground at all power supply pins. Consider the effect of temperature and aging on the capacitance value when using electrolytic capacitors.

(3) Ground Voltage

Ensure that no pins are at a voltage below that of the ground pin at any time, even during transient condition.

(4) Ground Wiring Pattern

When using both small-signal and large-current ground traces, the two ground traces should be routed separately but connected to a single ground at the reference point of the application board to avoid fluctuations in the small-signal ground caused by large currents. Also ensure that the ground traces of external components do not cause variations on the ground voltage. The ground lines must be as short and thick as possible to reduce line impedance.

(5) Thermal Consideration

Should by any chance the power dissipation rating be exceeded the rise in temperature of the chip may result in deterioration of the properties of the chip. In case of exceeding this absolute maximum rating, increase the board size and copper area to prevent exceeding the Pd rating.

(6) Recommended Operating Conditions

These conditions represent a range within which the expected characteristics of the IC can be approximately obtained. The electrical characteristics are guaranteed under the conditions of each parameter.

(7) Inrush Current

When power is first supplied to the IC, it is possible that the internal logic may be unstable and inrush current may flow instantaneously due to the internal powering sequence and delays, especially if the IC has more than one power supply. Therefore, give special consideration to power coupling capacitance, power wiring, width of ground wiring, and routing of connections.

(8) Operation Under Strong Electromagnetic Field

Operating the IC in the presence of a strong electromagnetic field may cause the IC to malfunction.

(9) Testing on Application Boards

When testing the IC on an application board, connecting a capacitor directly to a low-impedance output pin may subject the IC to stress. Always discharge capacitors completely after each process or step. The IC's power supply should always be turned off completely before connecting or removing it from the test setup during the inspection process. To prevent damage from static discharge, ground the IC during assembly and use similar precautions during transport and storage.

Operational Notes – continued

(10) Inter-pin Short and Mounting Errors

Ensure that the direction and position are correct when mounting the IC on the PCB. Incorrect mounting may result in damaging the IC. Avoid nearby pins being shorted to each other especially to ground, power supply and output pin. Inter-pin shorts could be due to many reasons such as metal particles, water droplets (in very humid environment) and unintentional solder bridge deposited in between pins during assembly to name a few.

(11) Unused Input Pins

Input pins of an IC are often connected to the gate of a MOS transistor. The gate has extremely high impedance and extremely low capacitance. If left unconnected, the electric field from the outside can easily charge it. The small charge acquired in this way is enough to produce a significant effect on the conduction through the transistor and cause unexpected operation of the IC. So unless otherwise specified, unused input pins should be connected to the power supply or ground line.

(12) Regarding the Input Pin of the IC

This monolithic IC contains P+ isolation and P substrate layers between adjacent elements in order to keep them isolated. P-N junctions are formed at the intersection of the P layers with the N layers of other elements, creating a parasitic diode or transistor. For example (refer to figure below):

When $GND > Pin A$ and $GND > Pin B$, the P-N junction operates as a parasitic diode.

When $GND > Pin B$, the P-N junction operates as a parasitic transistor.

Parasitic diodes inevitably occur in the structure of the IC. The operation of parasitic diodes can result in mutual interference among circuits, operational faults, or physical damage. Therefore, conditions that cause these diodes to operate, such as applying a voltage lower than the GND voltage to an input pin (and thus to the P substrate) should be avoided.

Figure xx. Example of monolithic IC structure

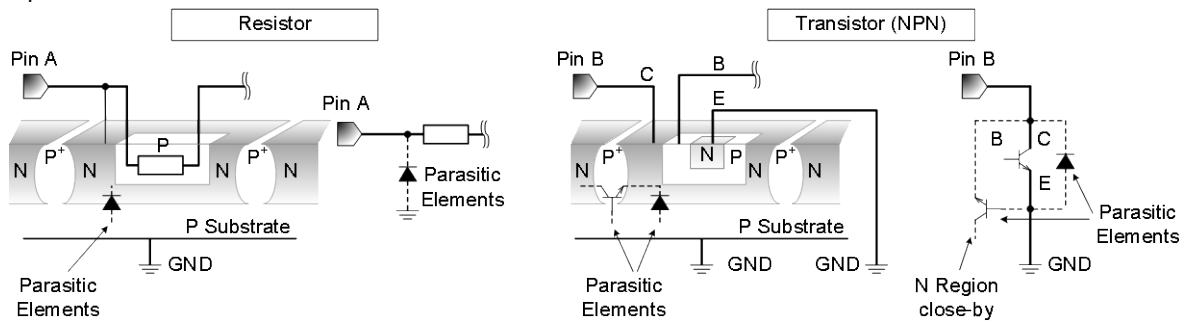

(13) Ceramic Capacitor

When using a ceramic capacitor, determine the dielectric constant considering the change of capacitance with temperature and the decrease in nominal capacitance due to DC bias and others.

(14) Area of Safe Operation (ASO)

Operate the IC such that the output voltage, output current, and power dissipation are all within the Area of Safe Operation (ASO).

(15) Over Current Protection Circuit (OCP)

This IC incorporates an integrated overcurrent protection circuit that is activated when the load is shorted. This protection circuit is effective in preventing damage due to sudden and unexpected incidents. However, the IC should not be used in applications characterized by continuous operation or transitioning of the protection circuit.

Notice

Precaution on using ROHM Products

- Our Products are designed and manufactured for application in ordinary electronic equipments (such as AV equipment, OA equipment, telecommunication equipment, home electronic appliances, amusement equipment, etc.). If you intend to use our Products in devices requiring extremely high reliability (such as medical equipment ^(Note 1), transport equipment, traffic equipment, aircraft/spacecraft, nuclear power controllers, fuel controllers, car equipment including car accessories, safety devices, etc.) and whose malfunction or failure may cause loss of human life, bodily injury or serious damage to property ("Specific Applications"), please consult with the ROHM sales representative in advance. Unless otherwise agreed in writing by ROHM in advance, ROHM shall not be in any way responsible or liable for any damages, expenses or losses incurred by you or third parties arising from the use of any ROHM's Products for Specific Applications.

(Note1) Medical Equipment Classification of the Specific Applications

JAPAN	USA	EU	CHINA
CLASS III	CLASS III	CLASS II b	CLASS III
CLASS IV		CLASS III	

- ROHM designs and manufactures its Products subject to strict quality control system. However, semiconductor products can fail or malfunction at a certain rate. Please be sure to implement, at your own responsibilities, adequate safety measures including but not limited to fail-safe design against the physical injury, damage to any property, which a failure or malfunction of our Products may cause. The following are examples of safety measures:
 - Installation of protection circuits or other protective devices to improve system safety
 - Installation of redundant circuits to reduce the impact of single or multiple circuit failure
- Our Products are designed and manufactured for use under standard conditions and not under any special or extraordinary environments or conditions, as exemplified below. Accordingly, ROHM shall not be in any way responsible or liable for any damages, expenses or losses arising from the use of any ROHM's Products under any special or extraordinary environments or conditions. If you intend to use our Products under any special or extraordinary environments or conditions (as exemplified below), your independent verification and confirmation of product performance, reliability, etc. prior to use, must be necessary:
 - Use of our Products in any types of liquid, including water, oils, chemicals, and organic solvents
 - Use of our Products outdoors or in places where the Products are exposed to direct sunlight or dust
 - Use of our Products in places where the Products are exposed to sea wind or corrosive gases, including Cl₂, H₂S, NH₃, SO₂, and NO₂
 - Use of our Products in places where the Products are exposed to static electricity or electromagnetic waves
 - Use of our Products in proximity to heat-producing components, plastic cords, or other flammable items
 - Sealing or coating our Products with resin or other coating materials
 - Use of our Products without cleaning residue of flux (even if you use no-clean type fluxes, cleaning residue of flux is recommended); or Washing our Products by using water or water-soluble cleaning agents for cleaning residue after soldering
 - Use of the Products in places subject to dew condensation
- The Products are not subject to radiation-proof design.
- Please verify and confirm characteristics of the final or mounted products in using the Products.
- In particular, if a transient load (a large amount of load applied in a short period of time, such as pulse. is applied, confirmation of performance characteristics after on-board mounting is strongly recommended. Avoid applying power exceeding normal rated power; exceeding the power rating under steady-state loading condition may negatively affect product performance and reliability.
- De-rate Power Dissipation (Pd) depending on Ambient temperature (Ta). When used in sealed area, confirm the actual ambient temperature.
- Confirm that operation temperature is within the specified range described in the product specification.
- ROHM shall not be in any way responsible or liable for failure induced under deviant condition from what is defined in this document.

Precaution for Mounting / Circuit board design

- When a highly active halogenous (chlorine, bromine, etc.) flux is used, the residue of flux may negatively affect product performance and reliability.
- In principle, the reflow soldering method must be used on a surface-mount products, the flow soldering method must be used on a through hole mount products. If the flow soldering method is preferred on a surface-mount products, please consult with the ROHM representative in advance.

For details, please refer to ROHM Mounting specification

Precautions Regarding Application Examples and External Circuits

1. If change is made to the constant of an external circuit, please allow a sufficient margin considering variations of the characteristics of the Products and external components, including transient characteristics, as well as static characteristics.
2. You agree that application notes, reference designs, and associated data and information contained in this document are presented only as guidance for Products use. Therefore, in case you use such information, you are solely responsible for it and you must exercise your own independent verification and judgment in the use of such information contained in this document. ROHM shall not be in any way responsible or liable for any damages, expenses or losses incurred by you or third parties arising from the use of such information.

Precaution for Electrostatic

This Product is electrostatic sensitive product, which may be damaged due to electrostatic discharge. Please take proper caution in your manufacturing process and storage so that voltage exceeding the Products maximum rating will not be applied to Products. Please take special care under dry condition (e.g. Grounding of human body / equipment / solder iron, isolation from charged objects, setting of Ionizer, friction prevention and temperature / humidity control).

Precaution for Storage / Transportation

1. Product performance and soldered connections may deteriorate if the Products are stored in the places where:
 - [a] the Products are exposed to sea winds or corrosive gases, including Cl₂, H₂S, NH₃, SO₂, and NO₂
 - [b] the temperature or humidity exceeds those recommended by ROHM
 - [c] the Products are exposed to direct sunshine or condensation
 - [d] the Products are exposed to high Electrostatic
2. Even under ROHM recommended storage condition, solderability of products out of recommended storage time period may be degraded. It is strongly recommended to confirm solderability before using Products of which storage time is exceeding the recommended storage time period.
3. Store / transport cartons in the correct direction, which is indicated on a carton with a symbol. Otherwise bent leads may occur due to excessive stress applied when dropping of a carton.
4. Use Products within the specified time after opening a humidity barrier bag. Baking is required before using Products of which storage time is exceeding the recommended storage time period.

Precaution for Product Label

QR code printed on ROHM Products label is for ROHM's internal use only.

Precaution for Disposition

When disposing Products please dispose them properly using an authorized industry waste company.

Precaution for Foreign Exchange and Foreign Trade act

Since concerned goods might be fallen under listed items of export control prescribed by Foreign exchange and Foreign trade act, please consult with ROHM in case of export.

Precaution Regarding Intellectual Property Rights

1. All information and data including but not limited to application example contained in this document is for reference only. ROHM does not warrant that foregoing information or data will not infringe any intellectual property rights or any other rights of any third party regarding such information or data.
2. ROHM shall not have any obligations where the claims, actions or demands arising from the combination of the Products with other articles such as components, circuits, systems or external equipment (including software).
3. No license, expressly or implied, is granted hereby under any intellectual property rights or other rights of ROHM or any third parties with respect to the Products or the information contained in this document. Provided, however, that ROHM will not assert its intellectual property rights or other rights against you or your customers to the extent necessary to manufacture or sell products containing the Products, subject to the terms and conditions herein.

Other Precaution

1. This document may not be reprinted or reproduced, in whole or in part, without prior written consent of ROHM.
2. The Products may not be disassembled, converted, modified, reproduced or otherwise changed without prior written consent of ROHM.
3. In no event shall you use in any way whatsoever the Products and the related technical information contained in the Products or this document for any military purposes, including but not limited to, the development of mass-destruction weapons.
4. The proper names of companies or products described in this document are trademarks or registered trademarks of ROHM, its affiliated companies or third parties.

General Precaution

1. Before you use our Products, you are requested to carefully read this document and fully understand its contents. ROHM shall not be in any way responsible or liable for failure, malfunction or accident arising from the use of any ROHM's Products against warning, caution or note contained in this document.
2. All information contained in this document is current as of the issuing date and subject to change without any prior notice. Before purchasing or using ROHM's Products, please confirm the latest information with a ROHM sales representative.
3. The information contained in this document is provided on an "as is" basis and ROHM does not warrant that all information contained in this document is accurate and/or error-free. ROHM shall not be in any way responsible or liable for any damages, expenses or losses incurred by you or third parties resulting from inaccuracy or errors of or concerning such information.



BM92T30MWV - Web Page

[Distribution Inventory](#)

Part Number	BM92T30MWV
Package	UQFN40V5050A
Unit Quantity	2500
Minimum Package Quantity	2500
Packing Type	Taping
Constitution Materials List	inquiry
RoHS	Yes